



WWW.ELECTRONICS-TUTORIALS.COM



•**NEW!** - Amazon [Electronic Component Packs](#). **Check out the [Amazon Electronic Component Packs page](#).**

What are the basics of regenerative radio receivers?

Foreword - by Ian C. Purdie VK2TIP

A regenerative radio receiver is unsurpassed in comparable simplicity, weak signal reception, inherent noise-limiting and agc action and, freedom from overloading and spurious responses. The regenerative radio receiver or, even super-regenerative radio receiver or, "regen" if you prefer, are basically oscillating detector receivers. They are simple detectors which may be used for cw or ssb when adjusted for oscillation or a-m phone when set just below point of oscillation. In contrast direct conversion receivers use a separate hetrodyne [oscillator](#) to produce a signal.

In the comprehensive electronic project presented here, Charles Kitchin, N1TEV has provided us with a three stage receiver project which overcomes some of the limitations of this type of receiver, principally the provision of an rf amplifier ahead of the detector.

We are indeed particularly grateful to "Chuck" Kitchin, a well noted technical author, for sharing this very valuable material with us to use, learn, experiment and above all, to enjoy.

Introduction to the regenerative radio receiver project designed by "Chuck" Kitchin, N1TEV

The radio described here is a two band short wave receiver which is both very sensitive and very portable. It receives AM, single sideband (SSB), and CW (code) signals over a frequency range of approximately 3.5 to 12MHz. This includes the 80, 40, and 30 meter Ham bands plus several international short wave bands.

The basic cost of this project should be about \$US35.00 per receiver, including the cost of the PC board.

This receiver is ideal for code practice and for general short wave listening although a certain amount of practice (and patience) is needed while the user learns how to tune and adjust the controls. This should be considered a medium skill level project. It was designed to be built by the average Ham under the mentorship of experienced "elmers" who can provide guidance on soldering, coil winding, troubleshooting, and operating the receiver. It is also a good "family" project. In the BARS club class, several parents built radios with their kids.

The following project is recommended for Ham radio clubs that are interested in introducing their membership to receiver "homebrewing".

The BARS Ham Radio club was fortunate to have several experienced "Elmers" including club president Ken Caruso, WO1N, club treasurer Bruce Anderson, W1LUS, New England Vice ARRL Director Mike Raisbeck, K1TWF, and

regenerative radio / homebrewing fanatic Chuck Kitchin, N1TEV. Many other members of the club helped out by donating parts or their time to this project.

The majority of the kit builders were graduates of the Chelmsford Charter School summer Ham radio class and their dads. However, the enthusiasm was widespread and several BARS members just had to build one too! Clubs planning to tackle a project like this should plan on a minimum of two sessions to complete the kits. You need to plan time to teach soldering techniques, component identification and schematic reading.

This project is designed to be built using the [FAR Circuits printed circuit board](#) (the name of the PC board is the same as this project's title). The use of this board is **HIGHLY** recommended as it greatly reduces the time spent soldering the circuit and avoids the many wiring errors that always occur during construction. It also helps prevent crossed connections and provides better performance than a hand wired board (because proper component location and shielding are designed into the PC board). The PC boards are available from FAR Circuits for \$5.00 each plus \$1.50 shipping for up to 3 boards. There is a group discount rate of 10% for 10 boards or more. You can contact FAR Circuits at 18N640 Field CT. Dundee, IL, 60118-9269. Tel: 847-836-9148 (voice and FAX) EMAIL: Farcir@ais.net Orders NOT accepted by email.

Simplified circuit description of the regenerative radio receiver project

As shown in Figure 1, this receiver consists of three sections: a radio frequency RF stage, a detector stage, and an audio amplifier stage. A bipolar [transistor](#) is used in the radio frequency stage, a JFET in the detector and the [audio amplifier](#) uses a low-cost IC. The RF stage, Q1 amplifies the antenna signals and provides isolation to prevent the radio's oscillations from causing interference to other receivers in the area.

JFET Q2 is a "regenerative" detector, which, by the use of positive feedback, greatly increases the receiver's sensitivity. It also supplies a local oscillation for the reception of CW and SSB signals. The audio stage IC1 amplifies the audio signal and provides enough output to drive headphones or a small speaker.

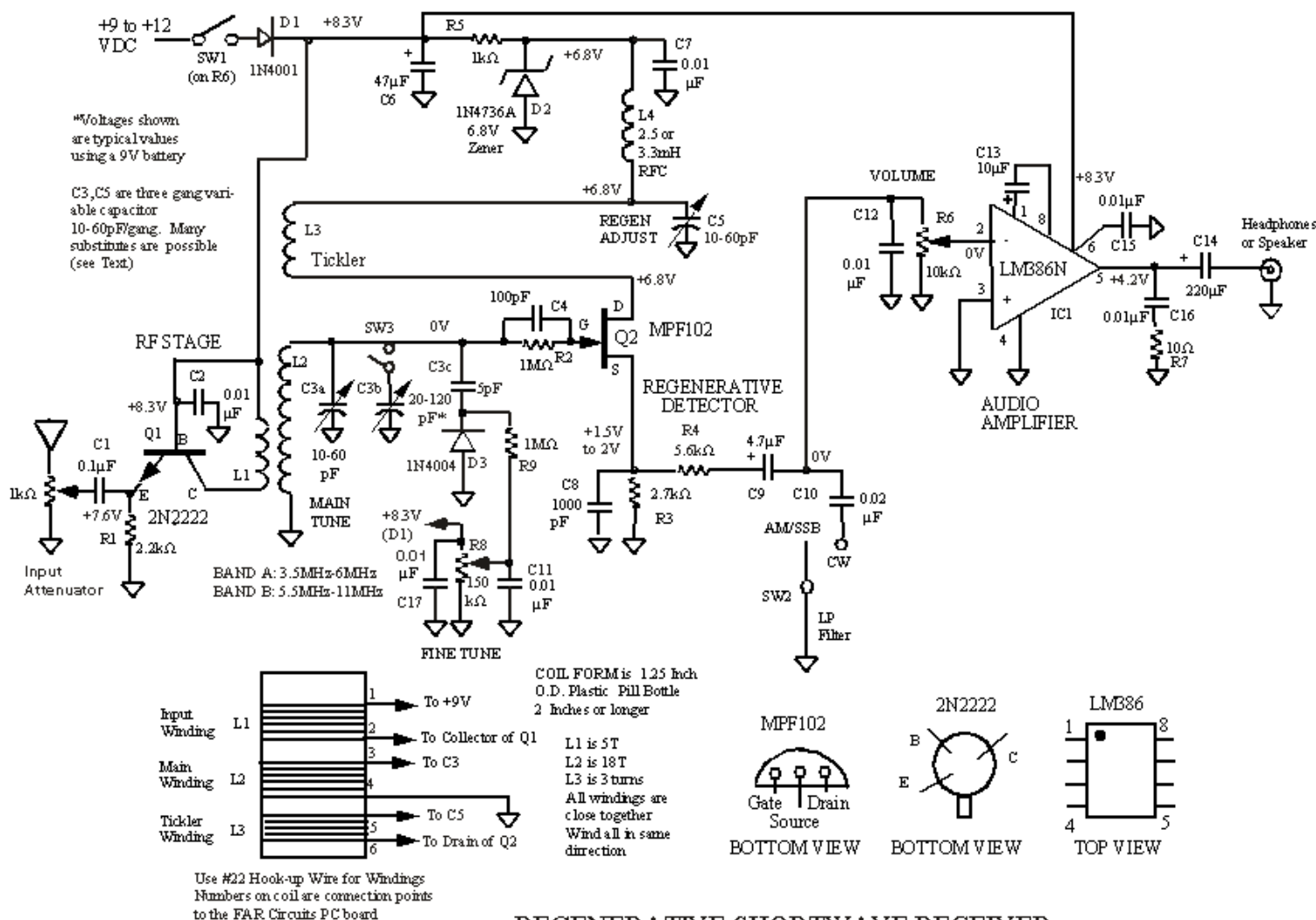

Figure 1 - Schematic diagram of the regenerative short wave receiver

For printable version of this schematic click here - PDF file 20.6 kB

Detailed circuit description of the regenerative radio receiver project

The signal from the antenna connects to a 1k Ohm potentiometer that serves as an input attenuator. This control is optional but highly recommended. It greatly increases the receiver's selectivity, especially on the international shortwave bands where signals are very strong. The input attenuator prevents "blocking" where a strong station near the received frequency can cause the receiver to lock on to the stronger station. The input attenuator also isolates the antenna's capacitance from the emitter of Q1. Too much capacitance at this point lowers the output impedance of the RF stage which reduces selectivity.

Q1 operates as an untuned, grounded-base RF amplifier, providing gain and isolating the detector's oscillations from the antenna. This RF stage provides ample gain and its high output impedance does not load L2 excessively. This helps provide very high selectivity.

C1 ac couples the antenna signal from Q1's emitter, which prevents shorting R1 should the antenna become grounded. L1 inductively couples the output signal from the JFET drain to the detector.

JFET Q2 operates as a tickler feedback or "Armstrong" regenerative detector circuit. Secondary winding, L2, and capacitors C3a (and C3b) select the received signal while tickler winding, L3, provides regenerative (in-phase) feedback. The circuit is basically a user-controlled oscillator to which an RF signal is coupled. The detector multiplies

the gain of the JFET and the selectivity of the coil by 1000 times or more. When operating below the threshold of oscillation, the detector serves as a high gain amplifier and AM detector. When oscillating, the detector heterodynes (mixes) its local oscillation with those of the signal to provide an audio "beat note".

Diode D3 functions quite well as a "[poor man's varactor](#)". The voltage from the battery is divided down by R8 and applied to D3 through series resistor R9. C11 removes any RF pick-up and also filters-out any noise as R8 is adjusted. Diode D3 is reversed biased by the voltage selected by R8. When this reverse bias is zero, D3 has about 50pF of capacitance; as R8 is turned- up this capacitance decreases, eventually to zero. Capacitor C3c reduces and linearizes the effect of R8. It also divides-down the [signal voltage](#) so that D3 does not become forward biased on strong RF signals.

R2/C4 are a "grid leak" arrangement that (together with R3) set a very high level of operating bias for the JFET, making regeneration control much smoother. C5 is a "throttle-capacitor" regeneration control, while [RF choke](#), L4, isolates the RF signal appearing at the regen capacitor from the power supply. [Zener diode](#) D2 regulates the drain voltage of the detector, to make the receiver very stable in the oscillating mode.

The audio output is extracted from the JFET source and travels through resistor R4 to the audio filters. R4 isolates C10 and C12 from R3 and C8 in the detector's source; otherwise, the detector may break into super regeneration. This can occur with high levels of RF feedback when a long RC time constant is used in the detector circuit. A large increase in either R2 or C4 would produce the same effect.

The audio signal travels to the volume control, R6. SW2, a single-pole, double-throw (center-off) toggle, can switch-in an additional capacitor (C12) to reduce the audio bandwidth for CW or SSB reception. An LM386 audio- amplifier IC provides adequate volume to drive headphones or a small speaker.

Diode D1 is a safety feature, which protects the receiver if the battery is connected backwards.

Collecting the parts for the regenerative radio receiver project

Most of the components for this project can be purchased at your local Radio Shack or by mail order from Digi-key or other supply houses. A complete parts list is shown below.

Parts list for the short wave regenerative radio receiver project

C1: 0.1 uF ceramic disc capacitor, 16V or higher.

C2, C7, C11, C12, C15, C16, : all 0.01 uF ceramic disc capacitor, 16V or higher.

C3a, C3b: Receiving type variable capacitor with one or more gangs. Minimum capacitance should be approx. 10pF or less and maximum capacitance 200 to 300pF. **(FRS, AES, OSE.)**

C3c: 5pF Mica or NPO ceramic capacitor, 16V or higher.

C4: 100pF Mica or NPO ceramic capacitor, 16V or higher.

C5: Receiving type variable capacitor with a minimum capacitance of approx. 10pF or less and a maximum capacitance of 100 to 200pF. **(FRS, AES, OSE).**

C6: 47 uF [electrolytic capacitor](#), 16V or higher.

C8: 1000pF mica or NPO ceramic capacitor, 16V or higher.

C9: 4.7 uF electrolytic capacitor, 16V or higher.

C10: 0.022 uF ceramic capacitor, 16V or higher.

C13: 10 uF electrolytic capacitor, 16V or higher.

C14: 220 uF electrolytic capacitor, 16V or higher.

D1: Any silicon rectifier diode (1N4001, 1N4004, etc).

D2: 1N4736A 6.8V Zener diode **(DK).**

All resistors below are 5%, 1/8W carbon composition or carbon [film types](#).

R1: 2K2 ohms W

R2, R9 : 1MW

R3: 2.7k W

R4: 5.6k W

R5: 1.0k W

R7: 10 W

R6: 10k W potentiometer, audio taper preferred with on/off switch (**RS, FRS**).

R8: Any 50k to 150k potentiometer, audio (log) taper preferred (**RS, FRS**).

L1 - L3: Pill bottle coil form using RS#22 gauge hookup wire (**see text**).

Q1: 2N2222 bipolar transistor (**DK, RS**),

Q2: MPF102 JFET Motorola transistor (**DK, RS**).

IC1: [National Semiconductor](#) LM386 amplifier (**DK, RS**).

SW1: Power on/off (part of R6) (**RS, FRS**).

SW2: Audio Filter switch: any small SPDT Toggle (**DK, RS**).

SW3: Band switch: any small SPDT Toggle or rotary switch (**DK, RS**).

RFC1: 3.3mH RF Choke (**Digi-Key** part #M7332-ND \$1.80).

Stereo headphone jack: (1/8 inch) for Walkman type headphones (**RS**).

Binding Posts: for Antenna and ground connections (**DK, RS, FRS**).

8 pin DIP: Socket for IC1 (optional).

9V Battery Holder

9V Battery (or use +12V source, see text).

Knobs: 1 large (3-4 inch) (**FRS, AES**), 4 "communications type" knobs (**RS**).

FAR CIRCUITS PC Board (**see text**).

One wooden base, 8.5 inches long by 5.5 inches wide (or wider).

Two wooden sides, 7 inches high by 5.5 inches wide (or wider).

One front panel, 10" wide by 7" high. Use three eighth inch Luan plywood.

One back panel, 10" long by 3" wide. Use one eighth inch masonite.

Fifty feet of hookup wire for the antenna, a short length for a ground connection. 6X32 machine screws 1" long (to mount variable capacitors).

Small brass screws (for mounting coil and PC board).

Speaker wire, nails, glue, Qdope, solder.

Walkman type headphones.

Available Options

Input attenuator. Any 1k ohm potentiometer.

Vernier Dial for Main or fine tuning control. Jackson Drive or use lower cost Japanese verniers from OSE or from You-Do-It Electronics (Needham, Ma).

Plug in Coil Forms to make a very wide range receiver (Long wave all the way up to 10M operation is possible) (AES part number PC-211).

5 Pin tube Socket for above (AES).

3 Banana jacks for external battery or power supply, red, black, blue. (DK, RS, FRS,AES).

RCA audio jack for connecting the receiver's output to an external amplifier or tape recorder (RS).

Keycode to suggested suppliers

RS: Your Local Radio Shack store.

DK: [Digi-Key corporation](#) p>701 Brooks Avenue South

Thief River Falls, MN 56701-0677

Phone: 218-681-6674

EMAIL: www.digikey.com

FRS: [Fair Radio Sales](#)

P.O Box 1105

1016 E. Eureka st.

Lima, Ohio 45802

Phone: 419-223-2196

EMAIL: fairradio@alpha.wcoil.com

AES: [Antique Electronics Supply](#)

6221 South Maple Avenue

Tempe Arizona 85283

Phone: 602-820-5411

EMAIL: www.tubesandmore.com

OSE: [Ocean State Electronics](#)

6 Industrial Drive

PO Box 1458

Westerly, RI 0289

Phone: 1-800-866-6626

EMAIL: www.oselectronics.com

Substituting parts in the regenerative receiver

Standard one, two, or three gang AM radio type variables, with different capacitances than those shown in the schematic, can be used for C3. Almost all will work fine, except that the receiver's frequency range will be somewhat different from the circuit shown here. Multi-band operation requires a multi-ganged capacitor (or plug-in coils) but a very decent single band receiver can be built using any single gang variable capacitor with a maximum capacitance of 200 to 400pF. If an air variable with a maximum capacitance over 200pF is used, the receiver will have more critical tuning, as more frequency range is packed into a single band. The addition of a vernier reduction drive or the use of a fine tuning control with a bit more range will solve this problem.

With the coil wired as shown in the schematic, 80 meter reception requires about 180pF total capacitance, 40 meters about 50pF. To change the received frequency range, simply add or subtract one or two turns from winding L2 (more turns will lower the frequencies received, fewer turns will tune higher frequencies). Alternatively, you can just solder (or switch-in) a mica capacitor in parallel with C3 (using the shortest leads possible) to lower the frequency range or in series with C3 to raise it.

The amount of regeneration control will also vary with the type of variable capacitor used. Many air variables may be substituted as long as the minimum capacitance is somewhere around 10-20pF and the maximum capacitance (with all gangs tied together) is 100pF or more. With multi-ganged capacitors, simply connect-up more gangs if more regeneration is needed, or disconnect gangs for less. You can also add or subtract a turn or two from the tickler winding.

Some general tips for group construction of the "regen" receiver

It is strongly recommended that, before group construction begins, the most experienced Ham should build the first receiver. This prototype receiver will then be available for everyone to look at while they are building their radio and it also will help discover any potential "bugs" before group construction begins. It is also essential that, once the prototype receiver is finished (and working properly), that the group copy it exactly, being especially careful to ground the frames of the air variable capacitors in exactly the same way.

Once the prototype is finished, all the parts can then be collected. They should be placed in individual boxes or bags and labeled with their part number (i.e.: all resistor R1's are in one box, R2's in another etc.) Individuals can then come up and take their parts a few at a time, as they wire their PC boards.

Avoiding "ground" loops in the regenerative receiver

As with any RF circuit, keep all wires as short as possible and be sure that all components are grounded directly to the PC board ground, using separate, very short, ground wires. Avoid "daisy-chain" grounds, where a ground wire connects to one component then it runs on to the next. This can introduce some very strange effects. With a "daisy-chain" the components are all grounded at different points along the wire, which may have strong RF signal levels across it. This is especially true in a regenerative circuit where RF levels are high.

Building the cabinet to house the regenerative receiver

This receiver is designed to use a wooden cabinet for several very good reasons. First, standard pine board and plywood are cheap and easy to find. They are also easy to fabricate using basic hand tools. Another important reason is that the main tuning coil of a regenerative receiver needs to be kept well away from any metal, otherwise both the sensitivity and the selectivity of the receiver will suffer.

But a metal cabinet CAN be made to work and, work well, as long as the coil form is kept at least three inches away from any metal on all sides. And a metal cabinet does have some advantages. It will provide good grounding and shielding, with generally better stability than a wooden enclosure. A metal cabinet also helps prevent any "hand capacitance" effects, although these should be minimal with this design.

Editorial comment - Ian Purdie VK2TIP

"An interesting article by my "mate" Bill Jones KD7S - How to build custom electronic and project enclosures from scrap plastic - absolutely brilliant. Excellent home learning project to construct home made enclosures".

[Be your own cabinetmaker](#) - by Bill Jones. Back to topic.....

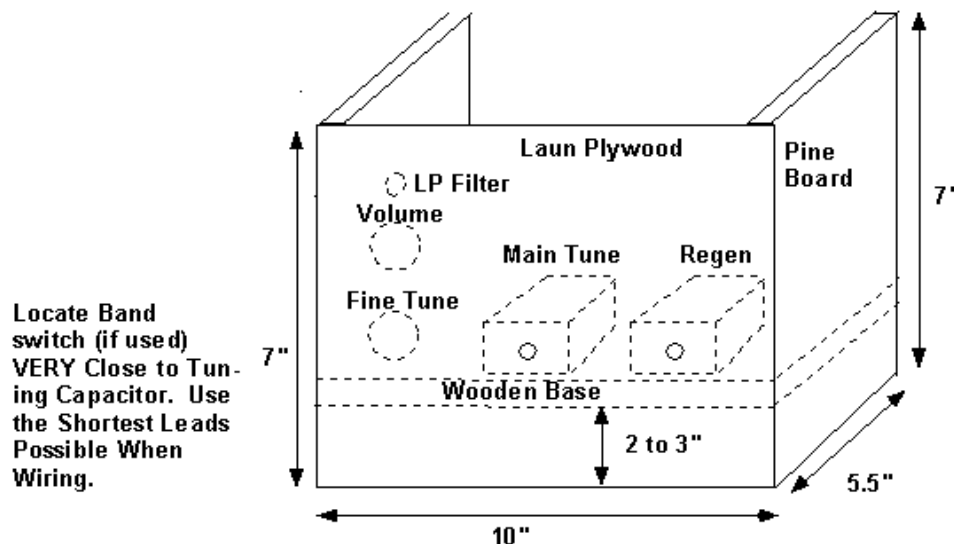

Figure 2 - Dimensions and layout for a typical regenerative detector wooden enclosure

Figure 2 provides mechanical dimensions and a typical layout for building a wooden enclosure for this regenerative short wave receiver.

If the wooden base is located at the bottom of the side boards and the air variable capacitors are directly attached to the base, spacers will be needed to lift the capacitors up high enough (above the base) to allow the use of large knobs on the front panel. You can eliminate this problem by simply attaching the wooden base a few inches above the bottom of the side boards. The variable caps can then be screwed down directly onto the base.

Parts layout of the regenerative short wave receiver

The photograph below shows the insides of a finished receiver. Note that the coil form containing windings L1, L2, and L3 should be located as close as possible to the PC board using the shortest leads possible. If long wires are used, they tend to radiate energy into other areas of the circuit and can cause some very strange effects in a regenerative set.

When mounting the two variable capacitors, solder a short wire to the body of each or attach the wire using one of the capacitor's mounting screws. The use of two very short connecting wires, one between each capacitor's frame and the PC board ground, is essential.

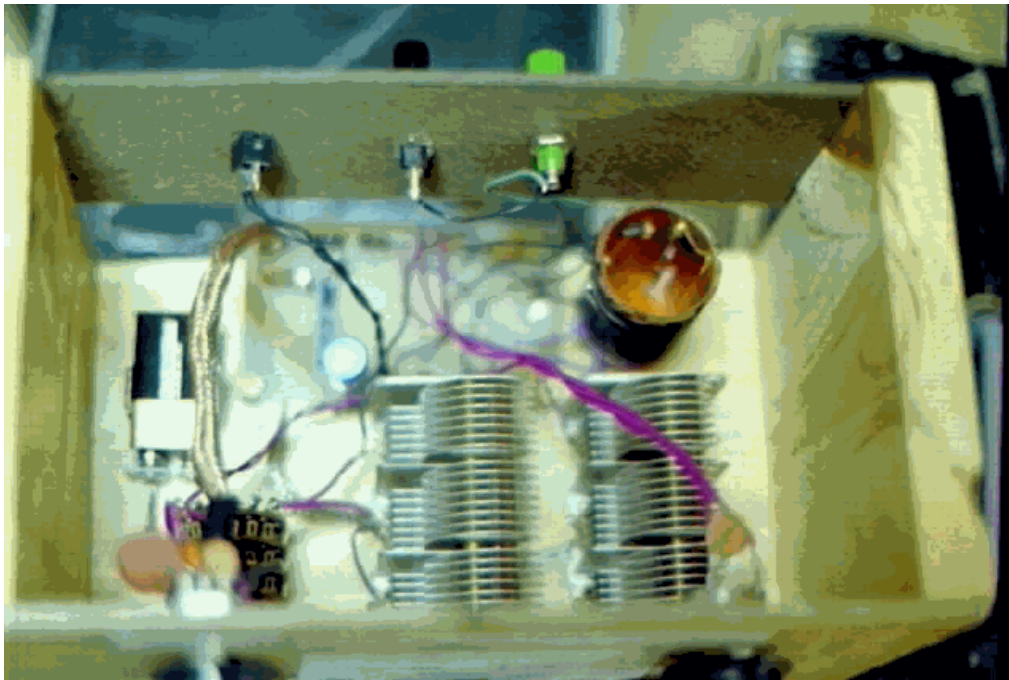

Figure 3 - The insides of a completed regenerative detector receiver

Try to arrange the receiver's layout so that all wires are kept as short as possible with the audio wiring physically separated from the RF (radio frequency) wiring. The volume and fine tuning controls should be mounted onto the front panel and then connected to the PC board using shielded wire. Be sure to run a separate ground wire between the ground terminal on the volume control and the PC board ground. This will prevent any "ground loop" effects.

The toggle switch, SW2 for the low pass filter should be mount right next to the volume control. capacitor C10 can be wired between this switch and the volume control using short leads. If C10 is wired into the PC board, be sure to use shielded wire between this connection and the volume control.

Wiring the short wave regenerative detector receiver circuit

Using the schematic of the short wave regenerative detector receiver and parts list as a guide, install and solder all the components into the PC Board. Be careful that diodes and capacitors are installed correctly: the striped end of the diodes is the cathode end and matches the stripe marked on the PC Board. Some of the capacitors are also polarized and are labeled + and so refer to the schematic and the PC board labeling to install these correctly. Also, be sure that the JFET (Q2) and bipolar transistor (Q1) are installed correctly. The flat side of Q2 is marked on the PC

board; the emitter of Q1 is the lead next to the tab (this is also indicated on the PC board). The base of Q1 is the center lead and the collector is the lead on the end opposite the emitter. You can substitute a PN2222 here, and it will work fine but be aware that the pinout for this transistor is different from that of the 2N2222. Most builders will want to leave out C12 and C17 from the PC board and simply wire these two capacitors right across the volume and fine tuning controls.

Winding the the short wave regenerative detector receiver coil

The receiver has one main coil with three windings: a primary (L1), a secondary (L2), and a tickler winding (L3).

Carefully make these three windings on each coil form, being sure to check the schematic diagram as you do so. Use Radio Shack #22 insulated hook-up wire for the windings. Be sure that the tickler winding (L3) is located on the ground side of the secondary winding (L2 see Figure 1 schematic).

It greatly simplifies construction if you use different color wires (of the same size) for each winding: for example, black for L1, red for L2, green for L3, etc. The coil form used is a 1.25 inch (32 mm) diameter plastic pill bottle 2.5 inches to 3 inches long. You can also use many other common items such as 1.25 inch (32 mm) diameter thin walled PVC sink drain pipe, and other plastic bottles of the same length and diameter. The exact frequency range (and the amount of regeneration) will vary with the diameter of the coil form used. It's best to stick with the size recommended, but it is possible to use many other types of coil forms.

When winding the coil, first drill two small holes in the coil form at the beginning of each winding. Then feed the wire through the first hole and out through the second. Before you start the winding, simply tie a knot at the point in the wire where it enters the form, this will keep the wire from loosening-up later on. Then wind the coil tightly onto the form counting the turns as you go. Keep the turns close together and try not to let the wire loosen up as you wind (this takes a little practice).

When the winding is finished, drill two more holes at the point on the form right where the winding ends (hold the end of the wire with the thumb of one hand while holding the drill in your other hand). Now, feed the wire through and tie a knot at the end to hold the coil in place. A second set of hands helps here.

Solder the wires from the coil form to the PC Board using the shortest possible lead lengths. When the receiver is finished (and working correctly) you can use Q dope to cement the windings firmly to the form. Avoid using standard glue as this will destroy the Q of the coil and the selectivity of the receiver (it's much better to have nothing here than to use standard glue).

Coil winding tips for group construction of the regenerative detector

For group construction, have a seasoned "Elmer" supervise the coil winding. Try to wind all the coils exactly the same as the prototype. All the coils should use the same diameter form, the same wire size, the same number of turns and the same spacing between turns. If all the coils are wound differently, the receivers can all be made to work properly but, an experienced Ham will be needed to fix them all up at the end of the project, (by adding or subtracting turns, etc) and this takes-up a lot of time.

So, a little bit more work in the beginning of the project will save a great deal of work at the end. Before soldering the three coil windings to the PC board, use an ohmmeter to check that there is continuity in each coil and have an "Elmer" check that all the windings have been made correctly.

Testing and "debugging" the short wave regenerative receiver

Once all the components and the three coil windings have been soldered to the board, temporarily connect a 9 volt battery to the anode of D1 and use a voltmeter to do a quick test. First, measure the voltage at the cathode of D1. It should be approx. 0.7V less than the battery voltage or about 8.3V. Next, measure the voltage at the cathode of D2. This should be approx. 6.8V (more or less).

This same voltage should be present on the regen capacitor and on the drain ("D") of Q2. Measure the voltage at the JFET source. This can vary a lot with individual devices but it should be approx. 1.5 to 2V. Then measure the voltage at the emitter of Q1. This should be approx. 0.7V less than the voltage on the base of Q1 or about 7.6V (8.3V-0.7V = 7.6V).

Finally, measure the voltage on pin 5 of IC1. This should be at mid supply or around 4.2V.

If all the voltages are correct, wire the two variable capacitors (C3 and C5) to the PC board using the shortest leads possible. Then wire the output jack J1 (using a RS stereo jack, the 2 "hot" leads go to C14, common to ground). Then wire the volume control to the board.

Test the audio stage first. Plug-in a set of headphones or connect a speaker to J1, and turn-up the volume control half way. You can just place your finger on the top of the volume control and listen for a buzz in the headphones.

Now test the detector. Use a clip lead to connect a short piece of wire (a foot or two but not more) to the primary winding (L1) right at the collector of Q1. Slowly turn up the regeneration control until the detector oscillates, producing a "live" sound (a large increase in background noise). If the detector refuses to oscillate, carefully check the wiring. If the wiring seems OK, try swapping the wires to the tickler winding.

Once the detector is oscillating, test the radio frequency RF amplifier stage, by connecting an antenna to C1 and a good ground to the PC board ground. You should be able to receive some stations, even during the daytime. If the circuit is working correctly, screw-down the PC board onto the wooden base. Drill a hole in the center of the pill bottle coil form and use a small brass screw to attach the coil to the wooden base right next to the PC board.

Next, mount the volume and fine tuning controls on the front panel. Drill three holes in the back panel about 1.5 inches (40 mm) apart and mount the antenna, and ground binding posts and headphone jack, J1. Connect a short ground wire between the ground post and the ground of the PC board. Connect the free end of C1 to the antenna post.

Final short wave regenerative receiver check out

This receiver should be very sensitive and it should also be stable, with freedom from any "strange effects".

When the receiver is finished, do the following tests to insure that everything is working properly. Connect an antenna wire and a ground wire to the receiver. Carefully check the receiver over its entire frequency range. There should be NO oscillation anywhere with the regen control set to minimum capacitance. Then check that oscillation occurs as the regeneration is turned up (again, check this over the entire frequency range). And **VERY IMPORTANT**, the set should go into, and out of, oscillation at exactly the same point on the regeneration control.

If the set oscillates all the time, even when the regen control is set to minimum capacitance, then 1 or 2 turns will need to be removed from the tickler winding (L3). This assumes that the coil has been connected to the PC board using the shortest wires possible, if not, then fix this before going further.

On some sets, you can just shove the tickler winding further down, so it's farther away from the main winding. Using the FAR circuits PC board and the coil dimensions given on the schematic, three turns on the tickler winding should be correct using a wide variety of capacitors for C5. If a multi gang capacitor is being used, you can try correcting fewer (or more) gangs to get the best regeneration control range.

If a hand-wired board (with a poor layout) is used or if the coil or ground wiring is too long, a hysteresis effect may occur on some sets. This usually shows-up at the lower frequencies around 80M.

Hysteresis is an effect where the circuit "snaps into" oscillation suddenly after turning the regen control way up and then the oscillation fails to go off until the control is turned way down. If this occurs, try connecting a second ground wire between the receiver's ground post and the frame of the regeneration capacitor (C5). On some receivers, two additional ground wires may be needed.

The use of a prototype receiver will help avoid any of these problems. Once the prototype is built, and working correctly, all the other receivers should closely follow its grounding and interconnection wiring.

The volume control should be able to be turned all the way up with out any "motor boating" effects. "Motor boating" should never occur if the set has been built using shielded wires for the volume and fine tuning controls. If it still "motorboats", the addition of a second 0.01uF capacitor, right across capacitor C12 (on the volume control) should cure this problem.

Short wave regenerative receiver set-up

Be sure to use a good ground connection with this receiver. This increases sensitivity and also makes the receiver more stable and easier to tune and operate. For a better (less noisy) ground, connect the receiver's ground wire to a cold water pipe or radiator.

The antenna can be almost any length of standard hook-up wire run out to a tree or even just dropped out of an upstairs window. A twenty to fifty foot length of wire will be entirely adequate for excellent short wave reception.

Tuning and regeneration adjustment of the short wave regenerative receiver

Some practice will be needed in learning to adjust the receiver for best performance. For AM reception, international

short wave stations, increase the regeneration level until the detector is just barely oscillating. Then use the main tuning capacitor (C3a) to get close to the desired signal. Reduce the regeneration level to just below oscillation and use the fine tuning control to finish tuning-in the station.

It's often a good idea to use two hands, one for tuning and the other for regeneration control. If the station is very weak, set the regen level slightly above oscillation and "zero beat" to the center of the carrier. This will provide you with VERY high sensitivity, typically better than 0.5 microvolt.

For CW (Morse code) reception, set the regeneration level just into oscillation. This will give you the highest sensitivity and selectivity. Tune the receiver to either side of the carrier to get the desired beat note. The CW beat note should be very stable, if it varies at all, simply increase the regeneration level.

SSB operation of the regenerative receiver is similar to CW except keep the regen level fairly high at all times to avoid "blocking". This can occur when strong stations lock the detector onto the center of the carrier.

Simply reducing the input signal level or increasing regeneration will prevent this. Strong SSB signals may need full regeneration to unblock. High regeneration levels should also eliminate any frequency drift.

For questions or comments on this shot wave regenerative radio receiver project, contact Chuck Kitchin, N1TEV direct at charles.kitchin@analog.com

C Kitchin REV H 3/16/99

Send VK2TIP feedback - no pun intended!

[Feedback to VK2TIP.](#)

Search

Google™
Custom Search

Got a question on this topic?

If you are involved in electronics then consider joining our ["electronics Questions and Answers"](#) news group to ask your question there as well as sharing your thorny questions and answers. Help out your colleagues!.

The absolute fastest way to get your question answered and yes, I **DO** read most posts.

This is a mutual help group with a very professional air about it. I've learn't things. It is an excellent learning resource for lurkers as well as active contributors.

RELATED TOPICS on regenerative radio receivers

[A three tube regenerodyne receiver - by Gary Johanson, WD4NKA](#)

[am radio receivers](#)

[crystal radio set](#)

[radio receiver basics](#)

[tuned radio frequency TRF receivers](#)

[reflex radio receivers](#)

[superhetrodyne radio receivers](#)

[fm radio receivers](#)

[capacitance](#)

[diodes](#)

[inductance](#)

[resonant frequency](#)

YOU ARE HERE: [HOME](#) > [RECEIVERS](#) > REGENERATIVE RADIO RECEIVERS

the author Ian C. Purdie, VK2TIP of www.electronics-tutorials.com asserts the moral right to be identified as the author of this web site and all contents herein. Copyright © 2000, all rights reserved. See [copying and links](#). These electronic tutorials are provided for individual private use and the author assumes no liability whatsoever for the application, use, misuse, of any of these projects or electronics tutorials that may result in the direct or indirect damage or loss that comes from these projects or tutorials. All materials are provided for free private and public use.

Commercial use prohibited without prior written permission from www.electronics-tutorials.com.

Copyright © 2000 - 2001, all rights reserved. URL - <http://www.electronics-tutorials.com/receivers/regen-radio-receiver.htm>

Updated 27th August, 2001

[Contact VK2TIP](#)