

# Simple, low cost AM SWBC Receiver

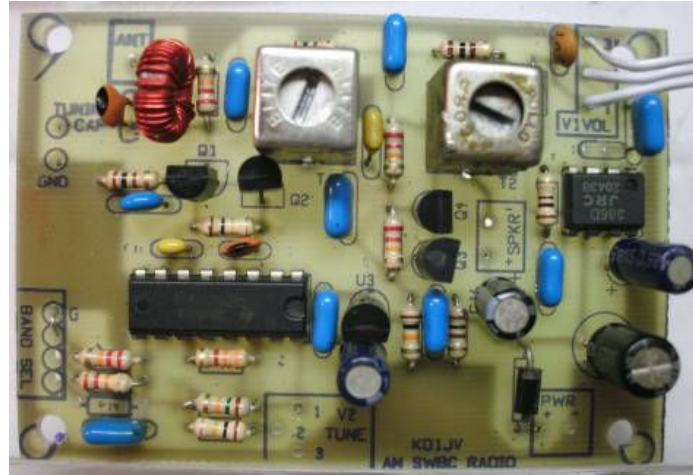

This project has been updated. This design was originally published 10 years ago (2004) and since then several parts have become discontinued and no longer available. The part numbers for many of the parts have changed so they come up as "not found" when you go looking for them. Since FAR circuits recently made up some boards for this project, I decided it was time to update the information.

This AM Short Wave Broadcast Receiver is a reasonably simple, but effective design and can be built at low cost. It requires no adjustments to get to work and is more or less fool proof. This makes it a great beginners project, with little or no test equipment. The radio can be built for about \$20.00, even if all new parts need to be bought. Many of the parts can be salvaged from an old AM/FM transistor or clock radio.

The radio will drive a small speaker to a comfortable volume. It will work with a short wire (3 feet or longer) or telescoping antenna. Tuning range is about 5.5 MHz to 10 MHz, using a coarse and fine tuning control. The radio can be powered by a 9 volt battery and draws about 21 ma of current. I would recommend using AA batteries or a small 9V AC adaptor to power the radio, as 9V radio batteries are expensive and won't last too long.

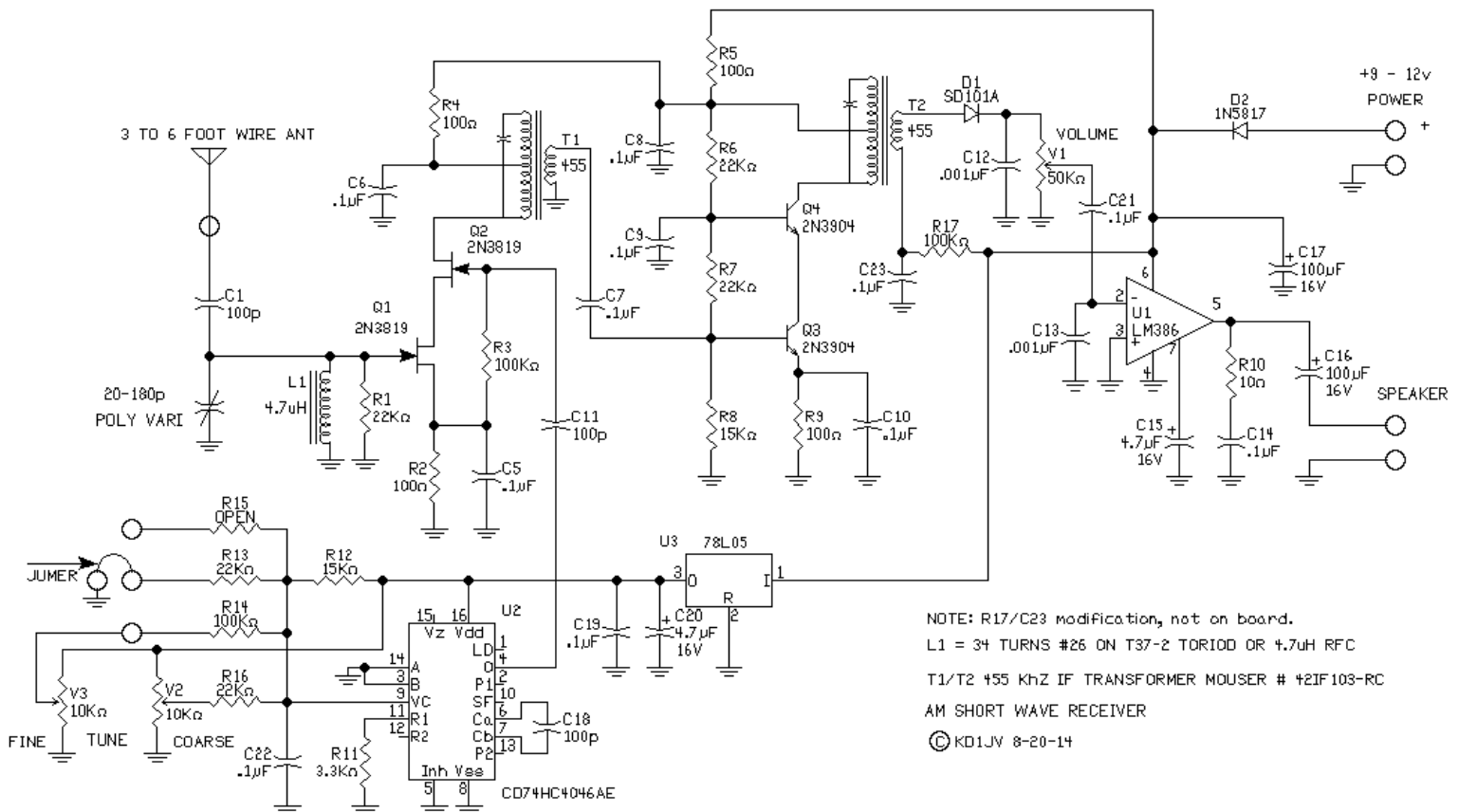

## How it works:

The antenna is coupled into the mixer through C1, 100 pfd. The input to the mixer is tuned to about the receive frequency of interest by L1 and a

poly-variable cap. The tuning cap can be a little hard to find as a new part, but can be salvaged from a dead or cheap AM/FM radio. (Poly-variables are available from [qrpkits.com](http://qrpkits.com) )

The mixer is an active stage using two JFETs in a cascode configuration. 2N3819's are shown, but just about any N channel JFET will work. The circuit was shamelessly borrowed from experimental Methods of RF Design" by W7OZI and co-authors. This mixer exhibits about 13 dB of conversion gain. It requires a large amplitude Local Oscillator drive, which makes directly coupling to the square wave output of the 74HC4046 VCO quite acceptable.

The output of the mixer is tuned to the IF frequency of 455 kHz by the IF transformer T1. This is coupled into a cascode amplifier consisting of Q2 and Q3. This amplifier basically combines a common emitter amplifier to which the input signal is coupled to, with a common base amplifier which adds additional gain, but keeps the amplifier quite stable. The output of this stage is again tuned with a 455 kHz IF transformer. The combination of the two IF transformers gives the radio some selectivity.

The AM signal is detected by a Shottky diode on the output of T2. A Shottky is used due to its low forward drop voltage, which reduces the level needed to detect a signal by at least 3 times over a silicon diode. The diode is connected to the volume control, which in turn goes to a LM386 audio amp. Forward bias was added to the detector diode to improve small signal sensitivity and improves the audio quality. R17 supplies the bias and C23 by-passes the RF. These parts need to be added to the bottom of the circuit board.

The Local Oscillator uses the Voltage tuned R/C oscillator section of a 74HC4046 PLL. This part is capable of generating a signal up to about 30 MHz. C18 and R11 comprise the R/C part of the oscillator. The R/C oscillator isn't very stable and constantly bounces around a few 100 Hz. Fortunately, the wide bandwidth of the IF and the nature of AM modulation is such that the instability is not noticeable to any great extent.

The original design was set up to just tune three SWBC bands and used a bank of three resistors selected by a switch to set the center of the tuning frequency to those bands. The TI chip tunes a wider frequency range so the voltages which need to be set for each band become fairly close to each other, making it difficult to come up with standard values for the divider. Plus there is the problem of parts tolerances which will cause the exact voltages needed for a specific frequency to vary unit to unit.

The best way to solve this dilemma was simply to make continuous tuning. Spanning large frequency range with a single turn pot makes for some very touchy tuning, so a fine tune control was added. Or you could use a 10 turn pot, but those are expensive. Trimmer resistors could have been used to set the center frequency for each band, but the board was not set up for that and now that boards have been made, too late to change.

**WARNING:** Not all 74HC4046s are created equal. The values shown are for the CD74HC4046N made by Texas Instruments (which is currently the only supplier of new through hole versions of this part). Parts made by a different manufacturer will require different values. Probably radically different values. The original CMOS 4046 parts will not work, as they have a much lower maximum operating frequency.

### Construction:

Parts list and assembly drawings at bottom of page.

If you can make your own circuit boards, the layout and component location screen is available as SWBC\_PCB.pdf . A premade circuit board is also available from FAR Circuits for \$5.00. (note, if you get the FAR board, there is a missing hole for one of the pins for T2 which you will have to drill).

Assembly is straight forward. It is easiest to start with the resistors, then the IC's, then the caps and so on. Note that the lead spacing for the resistors is very tight for 1/4 W resistors. You may want to use 1/8 W instead.

Adding some forward bias to the detector diode improves sensitivity and fidelity of the received signal. This is done by isolating the normally grounded pin of T2 secondary and adding a resistor between the pin and plus supply and adding a bypass cap between the pin and ground. Since the hole for this pin is missing from the board supplied by FAR circuits, using a common 1/16" drill bit to make the hole should be big enough. Just be careful not to short to the foil around the hole when adding the components to the pin. You could also use an XACTO knife to cut the foil.

A frequency counter can be connected to pin 4 of U2, the 74HC4046. This is a 5 volt square wave. A 6 digit LED counter with programmable IF offset can be bought direct from China for about \$15US. This makes a nice digital dial, but draws an additional 90 ma. Set the dial for negative IF offset. In this mode, it will add the IF offset to the VFO frequency. Note that these counters clip the input to 600 mv with diode clamps which will load down the output of the '4046. In this case, add a series resistor of 3.3K or thereabouts between the counter input and 4046 output.

The two IF transformers should come set close enough to the same frequency so they don't need adjustment. But if you must (and we must) try and peak the signals, adjust just one transformer and NEVER touch the other. Otherwise, you will chase the center frequency up and down the adjustment range of the coils!

The input tuning is sharp enough that it will require frequent re-peaking as the coarse frequency is tuned up and down the tuning range.

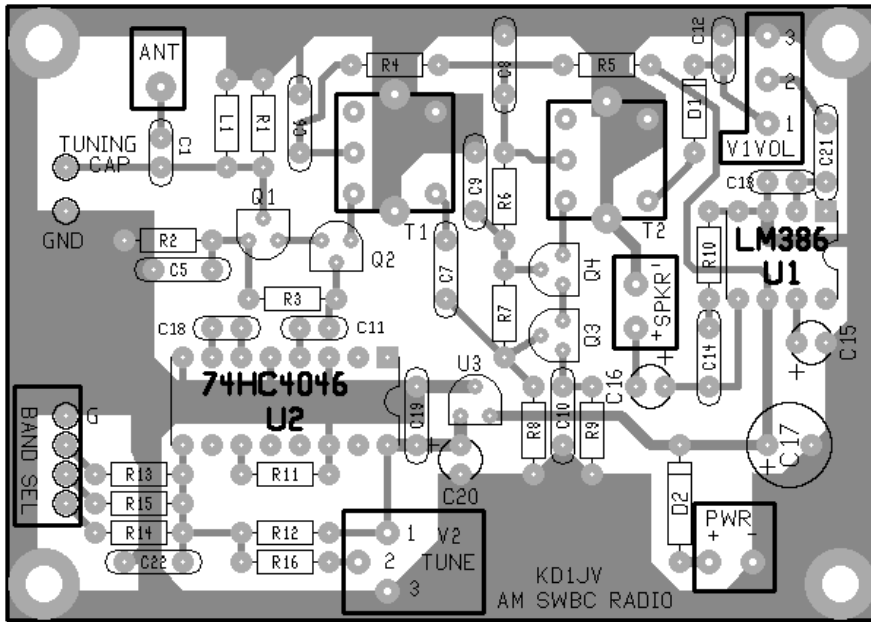

DRILL OVER SIZED HOLE OR COUNTER SINK FOIL TO ISOLATE PIN FROM GROUND

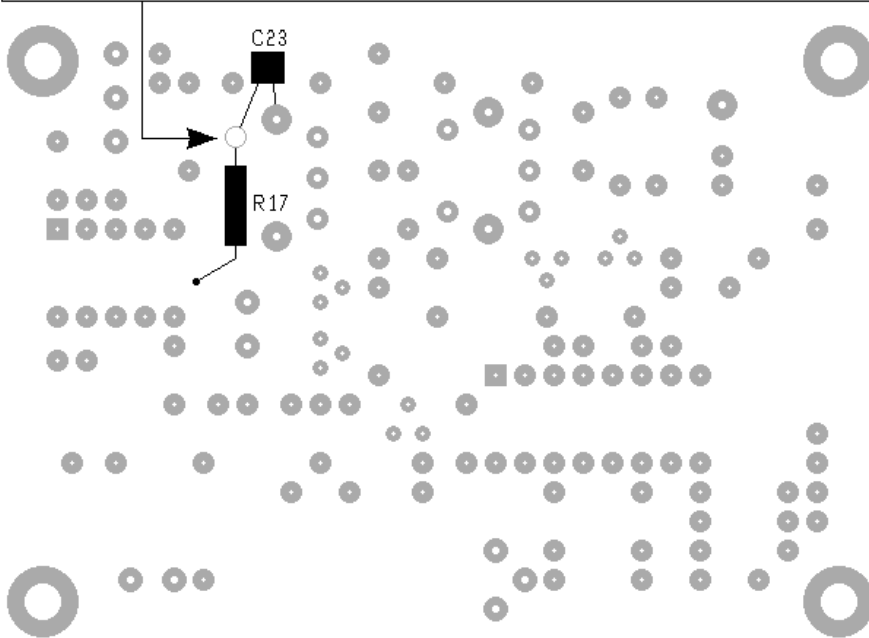

**Parts list**

| Designator          | Value                 | Mouser part number       | Price as of 11/04   |                 |
|---------------------|-----------------------|--------------------------|---------------------|-----------------|
| C                   | poly-variable 20-180p | salvage from AM/FM radio | or www.qrpkits.con  |                 |
| C5 - 10,14,19,21,22 | .1 uFd (10 TOTAL)     | 80-C317C104M5U           | \$0.12 each         |                 |
| C1, C11, C18        | 100 pFd NPO / C0G     |                          | \$0.06 each         |                 |
| C12,C13             | .001 uFd              | 140-50P2-102K            | \$0.08 each         |                 |
| C15,C20             | 4.7 uFd /16V          | 140-XRL16V4.7            | \$0.06 each         |                 |
| C16/C17             | 100 uFd / 16V         | 140-XRL16V47             | \$0.06              |                 |
| L1                  | 4.7 uHy               | 434-22-4R7               | \$0.20              | or 34T on T37-2 |
| R8/12               | 15K 5% 1/4W           | 291-15K                  | \$0.07 10 min order | (\$1.98 / 200!) |
| R2/4/5/9            | 100 ohm 5% 1/4W       | 291-100                  |                     |                 |
| R3/14/17            | 100K 5% 1/4W          | 291-100K                 |                     |                 |
| R1/6/7/13/16        | 22K 5% 1/4W           | 291-22K                  |                     |                 |
| R10                 | 10 ohm 5% 1/4W        | 291-10                   |                     |                 |
| R11                 | 3.3K 5% 1/4W          | 291-3.3K                 |                     |                 |

|         |                        |                  |                       |                     |
|---------|------------------------|------------------|-----------------------|---------------------|
| R15     | NOT USED               |                  |                       |                     |
| T1/T2   | 455 kHz IF transformer | 42IF103-RC       | \$1.07each (need two) |                     |
| V1/V3   | 10K linear pot         | 31VA401          | \$1.25 (need two)     |                     |
| V2      | 50K audio pot          | 31C501           | \$1.13                | 17mm with on/off sw |
| U1      | 74HC4046               | 595-CD74HC4046AE | \$0.66                | DIP-16              |
| U2      | LM386N                 | 926-LM386N/NOPB  | \$1.01                | DIP-8               |
| U3      | 78L05                  | 512-LM78L05ACZX  | \$0.27                | TO-92               |
| Q1/2    | 2N3819                 | 610-2N3819       | \$0.86 each           | TO-92               |
| Q2/3    | 2N3904                 | 512-2N3904BU     | \$0.19 each           | TO-92               |
| D1      | SD101A                 | 625-SD101A       | \$0.17                |                     |
| D2      | 1N5817                 | 615-1N5817       | \$0.14                |                     |
| speaker | 3" 8 ohm               | 253-4130         | \$1.91                |                     |

[HOME](#)